

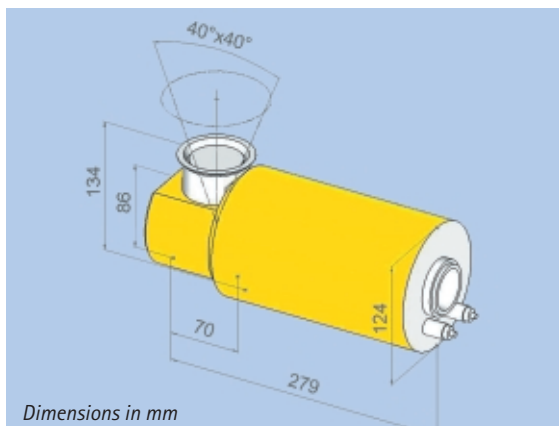

# Technical Data

## Y.TU 225-D02



Dimensions in mm

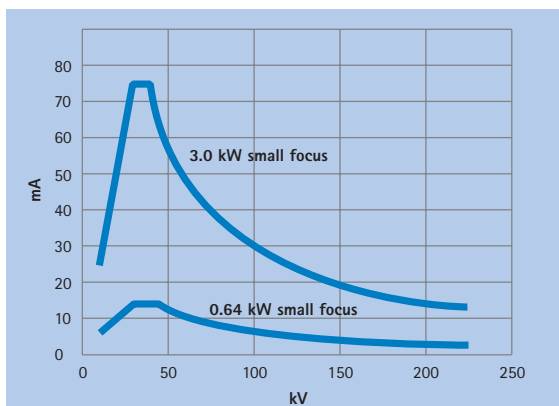

**Loading data:** shown are the max. permissible anode currents. Within the X-ray system these anode currents may be limited by power suppliers or generators.

<b>Max. tube voltage</b>	225 kV
<b>Focal spot size</b> (acc. EN12543) (acc. IEC336)	1.0 mm / 5.5 mm 0.4 / 3.0
<b>Max. power</b> (small / large focus)	0.64 kW / 3.0 kW
<b>Max. tube current at 225 kV</b>	2.8 mA / 13.0 mA
<b>Emergent beam angle</b>	40 °
<b>Inherent filtration<sup>1</sup></b>	0.8 mm Be + 4 mm Al
<b>Leakage radiation<sup>2</sup></b>	< 5.0 mSv/h
<b>Coolant</b>	Water
Max. inlet temperature	45 °C
Min. flow rate	4 l/min
<b>Environmental Conditions</b>	
Operation temperature	-10 °C...+40°C
Storage temperature	-25 °C...+70°C
Relative humidity	
- Operation	90 %
- Storage	95 %
<b>Weight</b>	11 kg
<b>H.V. connection</b>	Flange R12
<b>Approval</b>	PTB
<b>Order No.</b>	9421 172 31203

<sup>1</sup> Al-filter removable by using tools; Al-filter acc. DIN 54113 and SSI FS1989:2  
<sup>2</sup> Measured at 1.0 m distance from the focal spot with X-ray port closed and X-ray tube operating at full load.